

Version: 2.0

TECHNICAL SPECIFICATION
MODEL NO. : PM070WM2

The content of this information is subject to be changed without notice.
Please contact PVI or its agent for further information.

Customer's Confirmation

Customer _____

By _____

PVI's Confirmation

FOR MORE INFORMATION:
AZ DISPLAYS, INC.
75 COLUMBIA, ALISO VIEJO, CA 92656
[Http://www.AZDISPLAYS.com](http://www.AZDISPLAYS.com)

Confirmed By 中山峰树

Prepared By 黄承晶

Revision History

Rev.	Issued Date	Revised Contents
0.1	Jan 15, 2009	Preliminary
0.2	Mar 24, 2009	Modify Page 5 4. Mechanical Drawing of TFT-LCD Module Modify Page 10 7-2) Recommended Driving Condition for Back Light Modify Page 16 13. Optical Characteristics: Contrast Ratio & Viewing Angle data Add Page 16 13. Optical Characteristics: Brightness data & White Chromaticity Add Page 21 16. Packing Diagram
1.0	Apr 09, 2009	Add Page 10 7-2) Recommended Driving Condition for Back Light: Supply voltage of LED backlight Add Page 12 10. Block Diagram
2.0	Sep 18, 2009	Modify Page 5~6 4. Mechanical Drawing of TFT-LCD Module

TECHNICAL SPECIFICATION

CONTENTS

<i>NO.</i>	<i>ITEM</i>	<i>PAGE</i>
-	Cover	1
-	Revision History	2
-	Contents	3
1	Application	4
2	Features	4
3	Mechanical Specifications	4
4	Mechanical Drawing of TFT-LCD module	5
5	Input Terminals	7
6	Absolute Maximum Ratings	9
7	Electrical Characteristics	9
8	Pixel Arrangement	10
9	Display Color and Gray Scale Reference	11
10	Block Diagram	12
11	Interface Timing	13
12	Power On Sequence	16
13	Optical Characteristics	16
14	Handling Cautions	19
15	Reliability Test	20
16	Packing Diagram	21

1. Application

This data sheet applies to a color TFT LCD module, PM070WM2. The applications of panel are OA product, which requires high quality flat panel display.

Prime View assumes no responsibility for any damage resulting from the use of the device which does not comply with the instructions and the precautions in these specification sheets.

2. Features

- . Wide VGA (800*480 pixels) resolution
- . Amorphous silicon TFT LCD panel with LED back-light unit
- . Pixel in stripe configuration
- . Thin and light weight
- . Display Colors : 262,144 colors
- . +3.3V LVDS interface standard: THC63LVDF64A as receiver
- . +3.3V DC supply voltage for TFT LCD panel driving
- . Wide viewing angle
- . LVDS transmission interface

3. Mechanical Specifications

Parameter	Specifications	Unit
Screen Size	7.0(diagonal)	inch
Display Format	800×(R, G, B)×480	dot
Display Colors	262,144	
Active Area	152.4(H)×91.44(V)	mm
Pixel Pitch	0.1905(H)×0.1905(V)	mm
Pixel Configuration	Stripe	
Outline Dimension	166.3(W)×105.5 (H)×10.0(D) (typ.)	mm
Weight	244±15	g
Back-light	33-LED	
Surface treatment	Anti-glare and EWW Film	
Display mode	Normally white	
Gray scale inversion direction	6 o'clock	Note 13-1

4. Mechanical Drawing of TFT-LCD Module

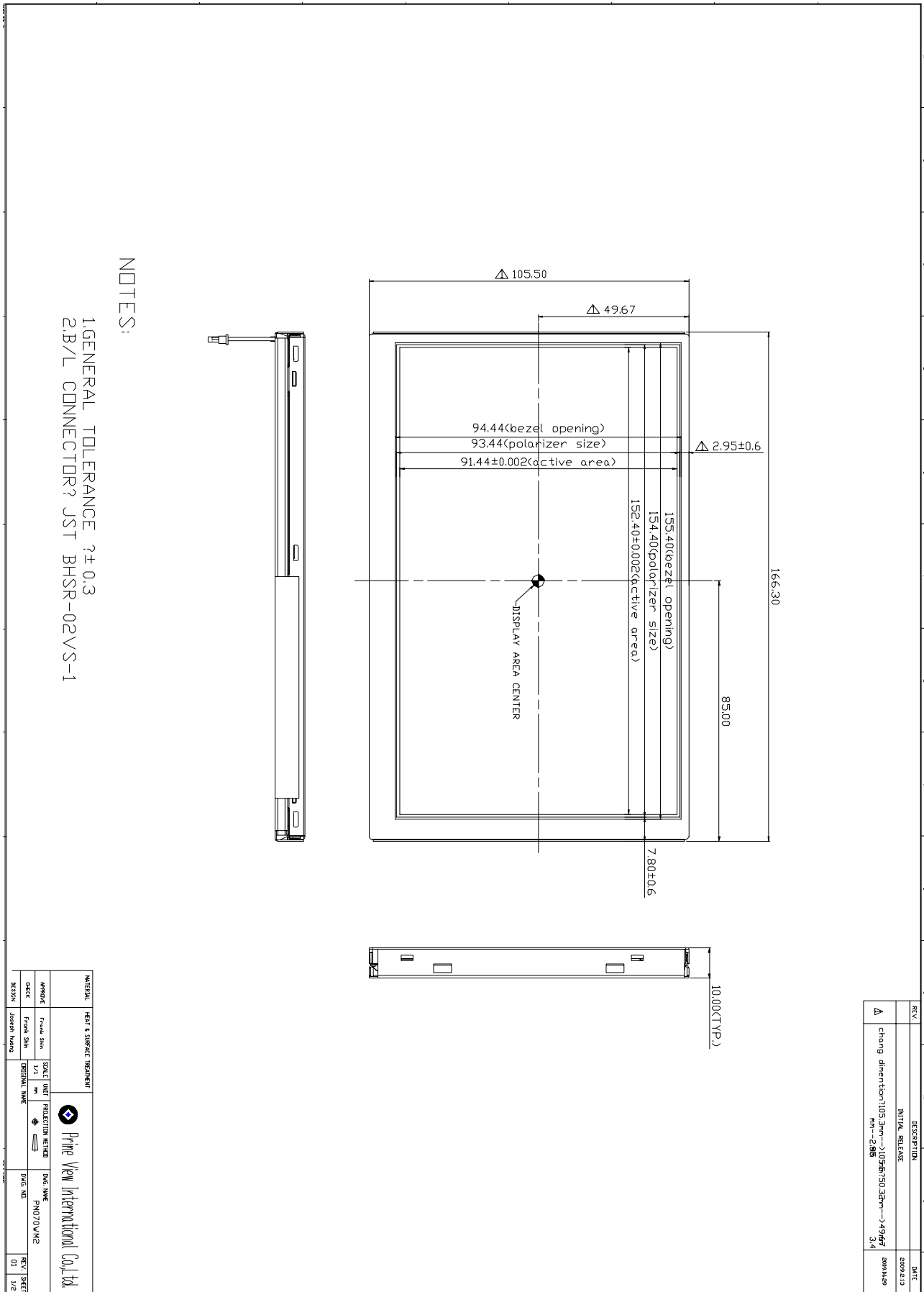

- NOTES**
- ① GENERAL TOLERANCE: ±0.3
 - ② CN1: B/L CONNECTOR: JST BHSR-02VS-1
 - ③ L VDS CONNECTOR: JDF19K-20P-1H(56X)HRS

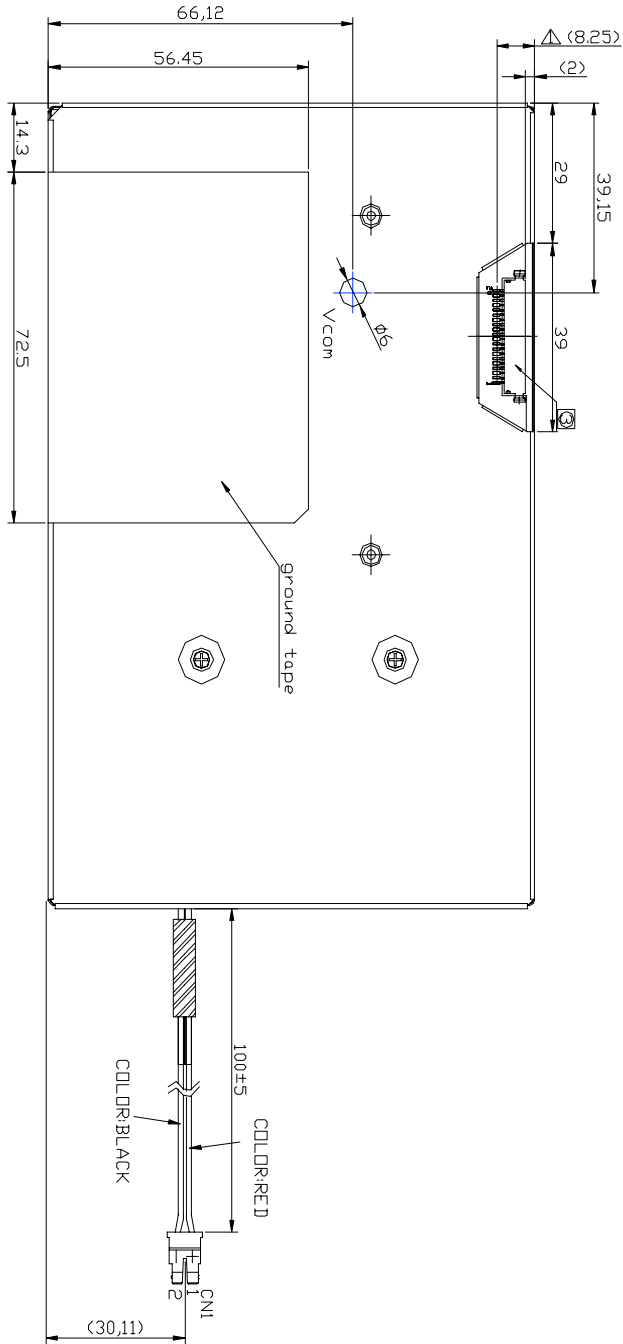

REV.	DESCRIPTION	DATE
Δ	INITIAL RELEASE	2009.2.13
	change dimension of 8.75mm-->8.25mm	2010.6.29

MATERIAL		PCB & SOLDER RESISTANCE		 Prime View International Co., Ltd.	
APPROVE	DATE	SCALE	PROJECTION METHOD	FIG. NO.	REV. SHEET
Checked in	1/1	mm	1st	PM070WM2	01 / 2
DESIGN	Checked in	DESIGNER NAME			
Joseph Huang					

5. Input Terminals

5-1) TFT-LCD Panel Driving

Connector type: DF19K-20P-1H (56) (HRS)

Pin No.	Symbol	Function	Remark
1	Vcc	+3.3V Power Supply	
2	Vcc	+3.3V Power Supply	
3	GND	Ground	
4	GND	Ground	
5	INO-	LVDS receiver signal channel 0	
6	INO+	LVDS receiver signal channel 0	
7	GND	Ground	
8	IN1-	LVDS receiver signal channel 1	
9	IN1+	LVDS receiver signal channel 1	
10	GND	Ground	
11	IN2-	LVDS receiver signal channel 2	
12	IN2+	LVDS receiver signal channel 2	
13	GND	Ground	
14	CLK-	LVDS receiver signal clock	
15	CLK+	LVDS receiver signal clock	
16	GND	Ground	
17	NC	No connection	
18	NC	No connection	
19	GND	Ground	
20	GND	Ground	

LVDS Interface Block Diagram

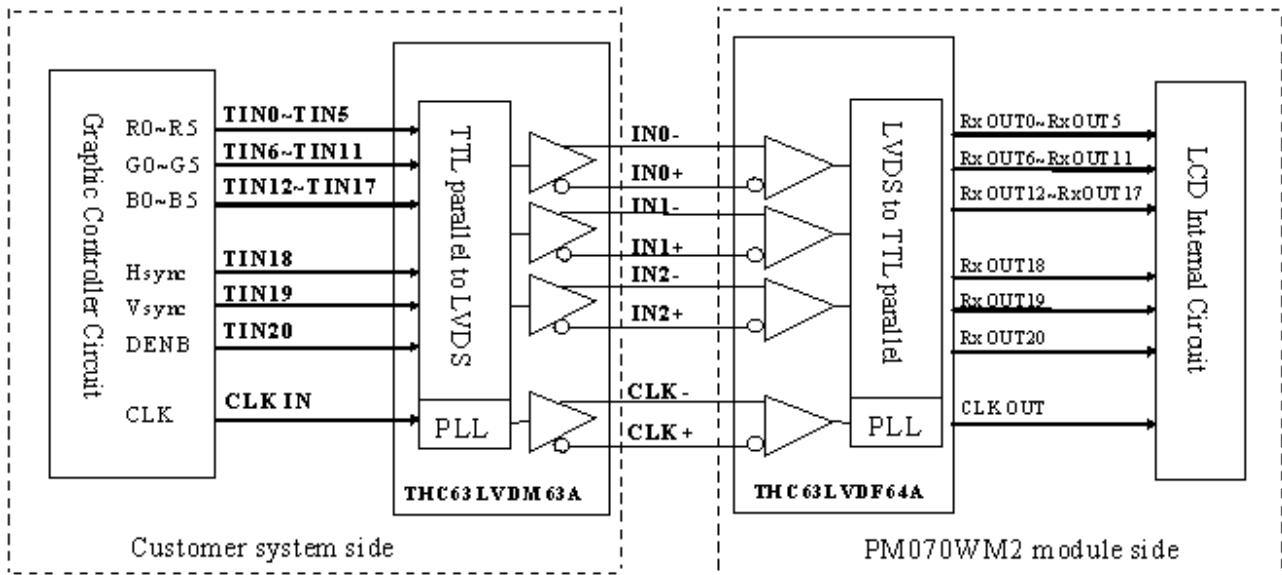

Recommended Transmitter (THC63LVDM63A THINE) to PM070WM2 interface Assignment

Input terminal of THC63LVDM63A		Graphic controller output signal		Output signal symbol	To PM070WM2 interface terminal (Symbol)
Symbol	No.	Symbol	Function		
TIN0	44	R0	Red pixel data (LSB)	} Tout0- } Tout0+	No.5 : IN0- No.6 : IN0+
TIN1	45	R1	Red pixel data		
TIN2	47	R2	Red pixel data		
TIN3	48	R3	Red pixel data		
TIN4	1	R4	Red pixel data		
TIN5	3	R5	Red pixel data(MSB)	} Tout1- } Tout1+	No.8 : IN1- No.9 : IN1+
TIN6	4	G0	Green pixel data (LSB)		
TIN7	6	G1	Green pixel data		
TIN8	7	G2	Green pixel data		
TIN9	9	G3	Green pixel data		
TIN10	10	G4	Green pixel data	} Tout2- } Tout2+	No.11 : IN2- No.12 : IN2+
TIN11	12	G5	Green pixel data(MSB)		
TIN12	13	B0	Blue pixel data(LSB)		
TIN13	15	B1	Blue pixel data		
TIN14	16	B2	Blue pixel data		
TIN15	18	B3	Blue pixel data	} Tout2+	No.11 : IN2- No.12 : IN2+
TIN16	19	B4	Blue pixel data		
TIN17	20	B5	Blue pixel data(MSB)		
TIN18	22	Hsync	Horizontal Synchronous Signal	} Tout2+	No.12 : IN2+
TIN19	23	Vsync	Vertical Synchronous Signal		
TIN20	25	DENB	Compound Synchronization signal		
CLK in	26	CLK	Data sampling clock	TCLK out- TCLK out+	No.14 : CLK - No.15 : CLK+

DENB input signal.

If customer wanted to off the DENB mode, you must keep the DENB always High or Low.

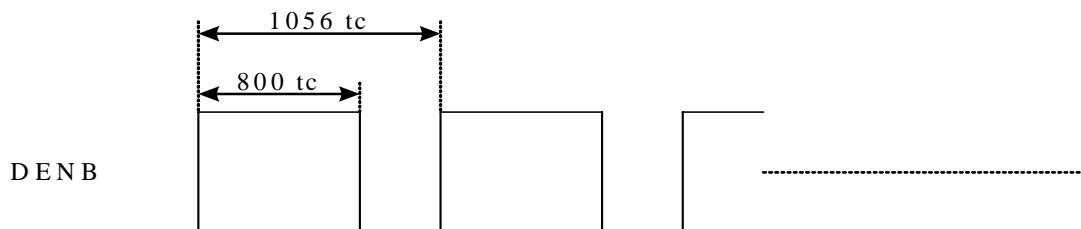

(tc: the period of sampling clock)

6. Absolute Maximum Ratings:

GND=0V, Ta=25□

Parameters	Symbol	MIN.	MAX.	Unit	Remark
Supply Voltage	V _{CC}	-0.3	+4.0	V	
Input Signals Voltage	V _{IN}	-0.3	V _{CC} +0.3	V	Note6-1
Storage Temperature	T _{st}	-40	+85	°C	
Operation Temperature	T _{op}	-30	+80	°C	

Note 6-1: LVDS signal.

7. Electrical Characteristics

7-1) Recommended Operating Conditions:

GND = 0V , Ta = 25□

Item	Symbol	Min.	Typ.	Max.	Unit	Remark
Supply Voltage	V _{CC}	3.0	3.3	3.6	V	
Current Dissipation	I _{CC}	-	130	195	mA	Note7-1
Total power consumption	P _{CC}		429	643.5	mW	V _{CC} = 3.3 V
LVDS Differential input high threshold	V _{TH}	-	-	100	mV	Note7-2
LVDS Differential input low threshold	V _{TL}	-100	-	-		

Note 7-1: To test the current dissipation of V_{CC}, using the “color bars” testing pattern shown as below

1	2	3	4	5	6	7	8
---	---	---	---	---	---	---	---

1. White
2. Yellow
3. Cyan
4. Green
5. Magenta
6. Red
7. Blue
8. Black

I_{CC} current dissipation testing pattern

Note7-2: Please refer to THC63LVDF64A specification by THINE Corporation. This LCD module conforms to LVDS standard.

7-2) Recommended Driving Condition for Back Light

Ta = 25

Parameter	Symbol	Min	TYP	MAX	Unit	Remark
Supply voltage of LED backlight	$V_{LED1\sim11}$	-	-	(11)	V	Note 7-3
Supply current of LED backlight	$I_{LED1\sim11}$	-	16	-	mA	Note 7 - 4
Backlight Power Consumption	P_{LED}	-	-	1.94	W	Note 7-3 /Note 7-5

Note 7-3: $I_{LED} = 16\text{mA}$, constant current

Note 7-4: The LED driving condition is defined for each LED module. (3 LED Serial)

Input current = $16\text{mA} * 11 = 176\text{mA}$

Note 7-5: $P_{LED} = V_{LED1} * I_{LED1} + V_{LED2} * I_{LED2} \dots + V_{LED10} * I_{LED10} + V_{LED11} * I_{LED11}$

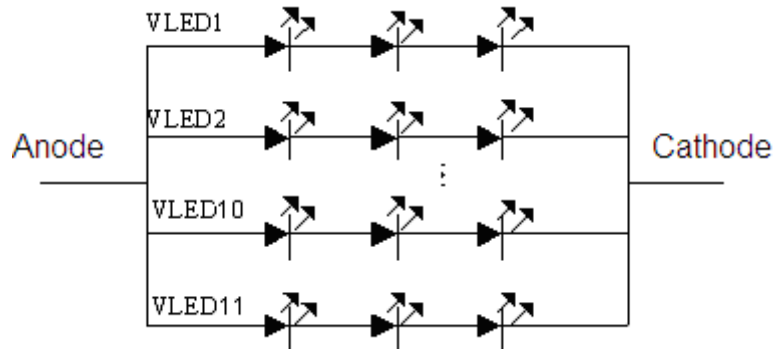

7-3) Backlight driving

Connector type: JST BHSR-02VS-1N, PIN No 2 pin

Pin No	Symbol	Description	Remark
1	+	Input terminal (Anode)	Wire color : Red
2	-	Input terminal (Cathode)	Wire Color : Black

8. Pixel Arrangement

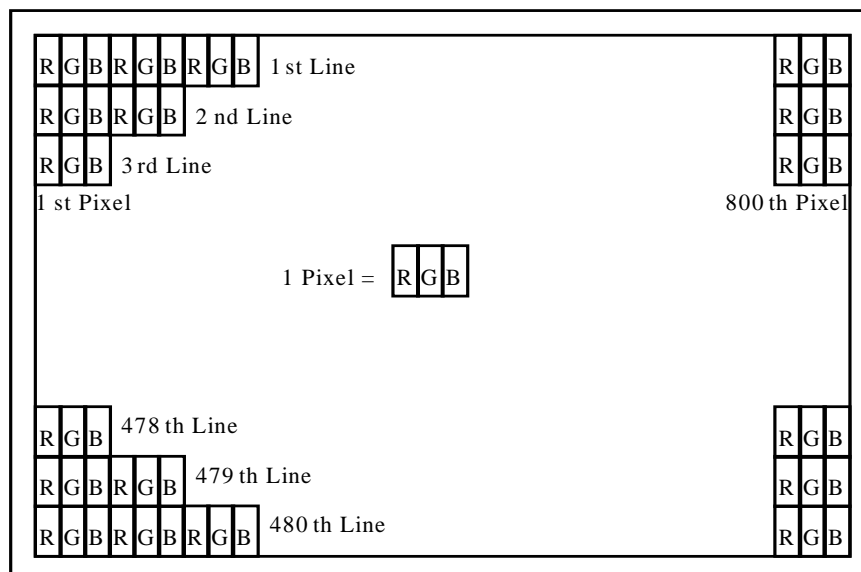

9. Display Color and Gray Scale Reference

Color		Input Color Data																	
		Red						Green						Blue					
		R5	R4	R3	R2	R1	R0	G5	G4	G3	G2	G1	G0	B5	B4	B3	B2	B1	B0
Basic Colors	Black	0	0	0	0	0	0	0	0	0	0	0	0	0	0	0	0	0	0
	Red (63)	1	1	1	1	1	1	0	0	0	0	0	0	0	0	0	0	0	0
	Green (63)	0	0	0	0	0	0	1	1	1	1	1	1	0	0	0	0	0	0
	Blue (63)	0	0	0	0	0	0	0	0	0	0	0	0	1	1	1	1	1	1
	Cyan	0	0	0	0	0	0	1	1	1	1	1	1	1	1	1	1	1	1
	Magenta	1	1	1	1	1	1	0	0	0	0	0	0	1	1	1	1	1	1
	Yellow	1	1	1	1	1	1	1	1	1	1	1	1	0	0	0	0	0	0
	White	1	1	1	1	1	1	1	1	1	1	1	1	1	1	1	1	1	1
Red	Red (00)	0	0	0	0	0	0	0	0	0	0	0	0	0	0	0	0	0	0
	Red (01)	0	0	0	0	0	1	0	0	0	0	0	0	0	0	0	0	0	0
	Red (02)	0	0	0	0	1	0	0	0	0	0	0	0	0	0	0	0	0	0
	Darker																		
	↓	↓	↓	↓	↓	↓	↓	↓	↓	↓	↓	↓	↓	↓	↓	↓	↓	↓	↓
	Brighter																		
	Red (61)	1	1	1	1	0	1	0	0	0	0	0	0	0	0	0	0	0	0
	Red (62)	1	1	1	1	1	0	0	0	0	0	0	0	0	0	0	0	0	0
Red (63)	1	1	1	1	1	1	0	0	0	0	0	0	0	0	0	0	0	0	
Green	Green (00)	0	0	0	0	0	0	0	0	0	0	0	0	0	0	0	0	0	0
	Green (01)	0	0	0	0	0	0	0	0	0	0	0	1	0	0	0	0	0	0
	Green (02)	0	0	0	0	0	0	0	0	0	0	1	0	0	0	0	0	0	0
	Darker																		
	↓	↓	↓	↓	↓	↓	↓	↓	↓	↓	↓	↓	↓	↓	↓	↓	↓	↓	↓
	Brighter																		
	Green (61)	0	0	0	0	0	0	1	1	1	1	0	1	0	0	0	0	0	0
	Green (62)	0	0	0	0	0	0	1	1	1	1	1	0	0	0	0	0	0	0
Green (63)	0	0	0	0	0	0	1	1	1	1	1	1	0	0	0	0	0	0	
Blue	Blue (00)	0	0	0	0	0	0	0	0	0	0	0	0	0	0	0	0	0	0
	Blue (01)	0	0	0	0	0	0	0	0	0	0	0	0	0	0	0	0	0	1
	Blue (02)	0	0	0	0	0	0	0	0	0	0	0	0	0	0	0	0	1	0
	Darker																		
	↓	↓	↓	↓	↓	↓	↓	↓	↓	↓	↓	↓	↓	↓	↓	↓	↓	↓	↓
	Brighter																		
	Blue (61)	0	0	0	0	0	0	0	0	0	0	0	0	1	1	1	1	0	1
	Blue (62)	0	0	0	0	0	0	0	0	0	0	0	0	1	1	1	1	1	0
Blue (63)	0	0	0	0	0	0	0	0	0	0	0	0	1	1	1	1	1	1	

10. Block Diagram

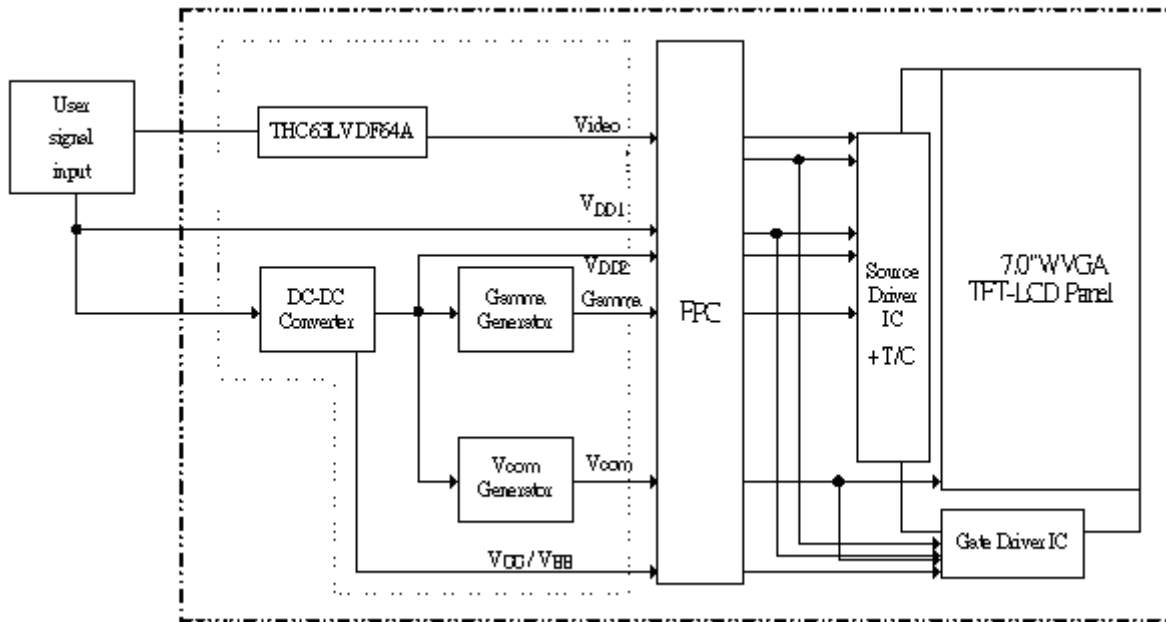

11. Interface Timing
11-1) Timing Parameters

		Symbol	Min.	Typ.	Max.	Unit	Remark	
Power supply		VCC	3.0	3.3	3.6	V		
CLK	Frequency	1/tc	-	32	-	MHz		
		tc	-	31.25	-	ns		
HSYNC	Period	Hp	-	33	-	us		
			-	1056	-	tc		
	Display period	Hdp	-	800	-	tc		
	Pulse width	Hpw	-	128	-	tc		
	Back-porch	Hbp	-	88	-	tc		
	Front-porch	Hfp	-	40	-	tc		
	Hpw+Hbp			-	216	-	tc	
	Hsync-CLK	Hhc	10	-	Tc-10	ns		
	Vsync-Hsync	Hvh	0	0	200	tc		
VSYNC	Period	Vp	-	17.325	-	ms		
			-	525	-	Hp		
	Display period	Vdp	-	480	-	Hp		
	Pulse width	Vpw	-	2	-	Hp		
	Back-porch	Vbp	-	33	-	Hp		
	Front-porch	Vfp	-	10	-	Hp		
	Vpw+Vbp			-	35	-	Hp	
DENB	Horizontal scanning period	T1	860	1056	1064	tc		
	Horizontal display period	T2	-	800	-	tc		
	Vertical display period	T3	-	480	-	T1		
	Frame cycling period	T4	490	525	590	T1		
R,G,B	CLK-DATA	Dcd	10	-	-	ns		
	DATA-CLK	Ddc	8	-	-	ns		

11-2) The Timing Diagram

(A) Input signal range

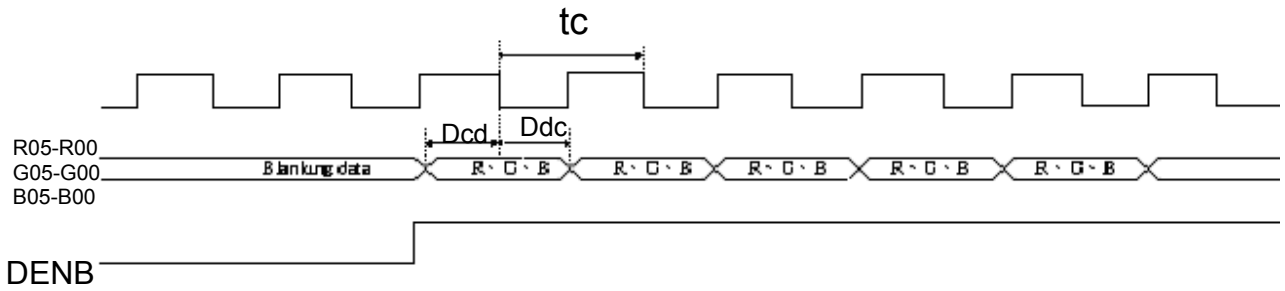

(B) HSYNC timing

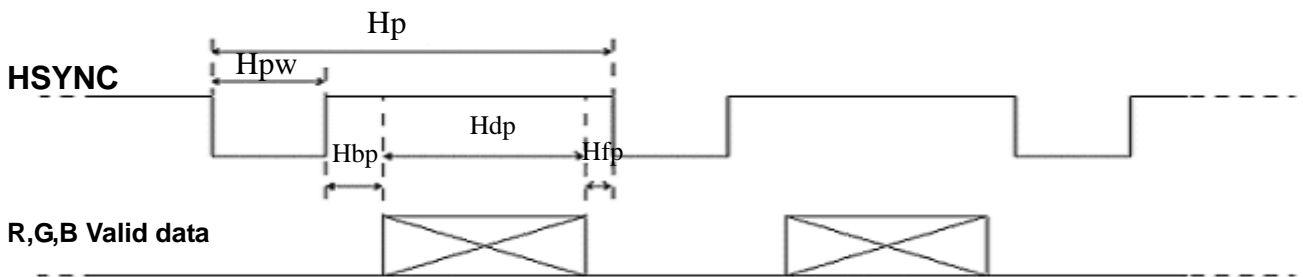

(C) CLK, HSYNC relationship



(D) HSYNC, VSYNC relationship

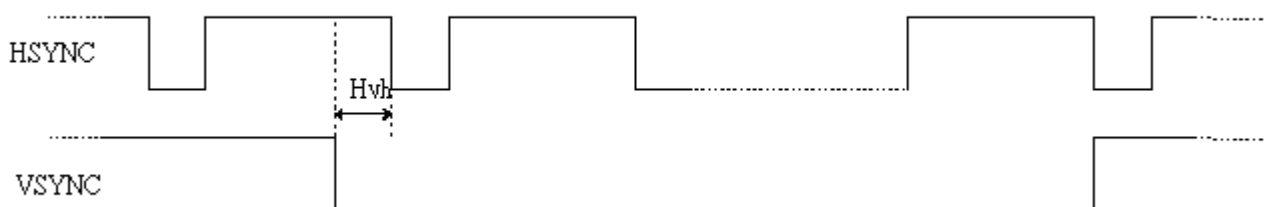

(E) VSYNC timing

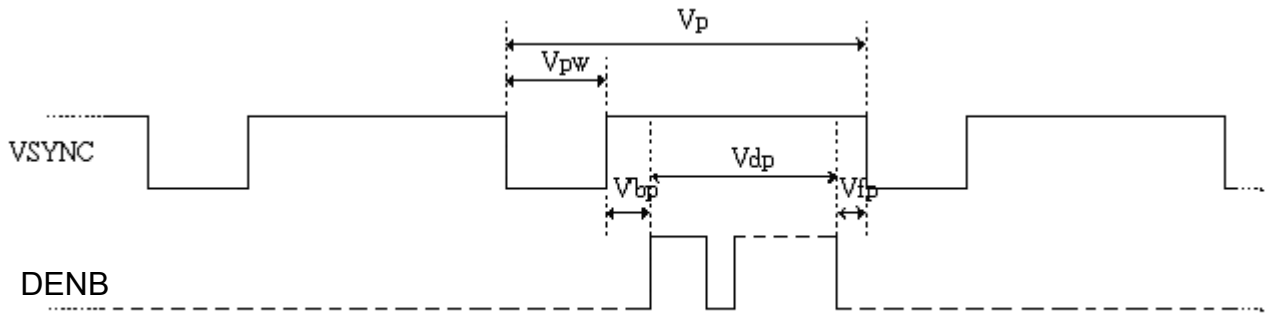

(F) DENB timing

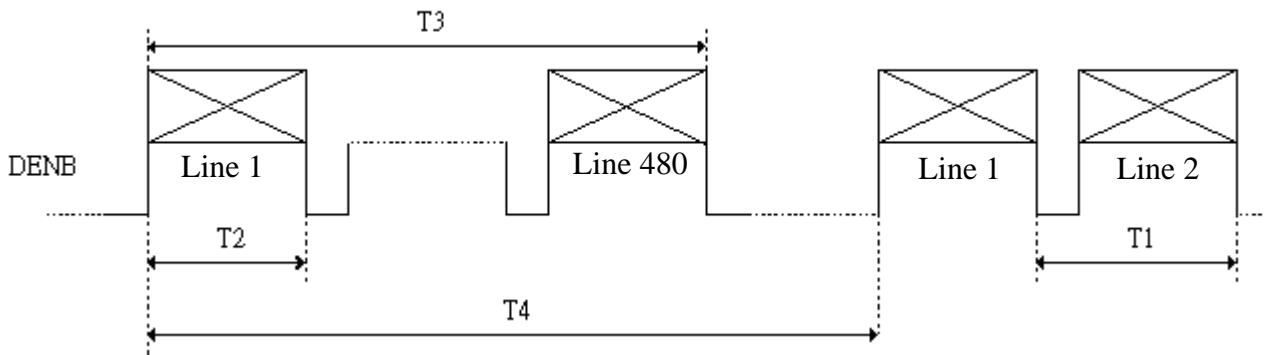

12. Power on Sequence

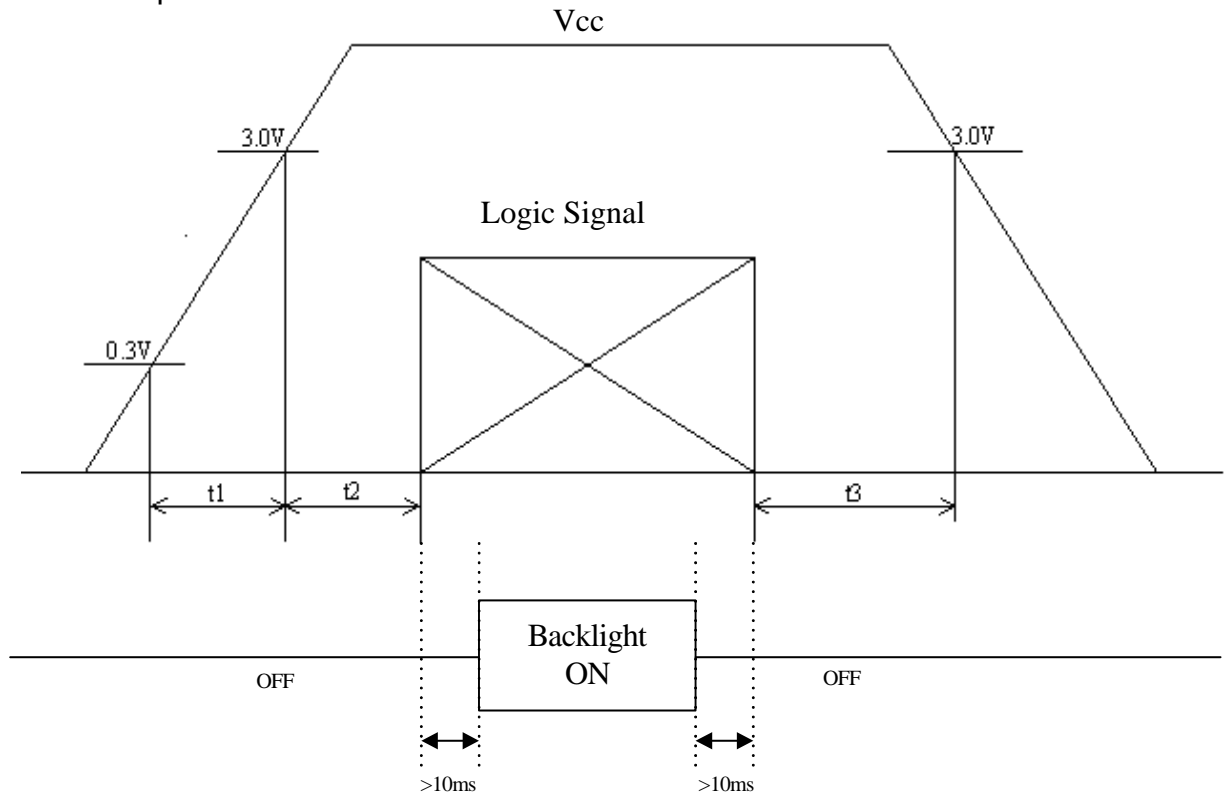

1. $0 < t1 \leq 20\text{ms}$
2. $0 < t2 \leq 50\text{ms}$
3. $0 < t3 \leq 1\text{s}$

13. Optical Characteristics

13-1) Specification:

 $T_a = 25^\circ\text{C}$

Parameter	Symbol	Condition	MIN.	TYP.	MAX.	Unit	Remarks	
Viewing Angle	Horizontal	$\theta \leq 10$	± 75	± 80	-	deg	Note 13-1	
	Vertical		$\theta 12$	55	60	-		deg
			$\theta 11$	65	70	-		deg
Contrast Ratio	CR	$\theta = 0^\circ$	600	800	-	-	Note 13-2	
Response time	Rise	$\theta = 0^\circ$	-	5	10	ms	Note 13-3	
	Fall		Tf	-	15	20		ms
Brightness	L	$\theta = 0^\circ / \varphi = 0$	350	400	-	cd/m^2		
LED Life Time		$+25^\circ\text{C}$	20000	30000	-	hrs	Note 13-4	
Luminance Uniformity	U	-	70	75	-	%	Note 13-5	
White Chromaticity	x	-	0.27	0.31	0.35	-		
	y	-	0.30	0.34	0.38	-		
Cross Talk	CTK	$\theta = 0^\circ$	-	-	3.5	%	Note 13-6	

Note 13-1: The definitions of viewing angles are as follow.

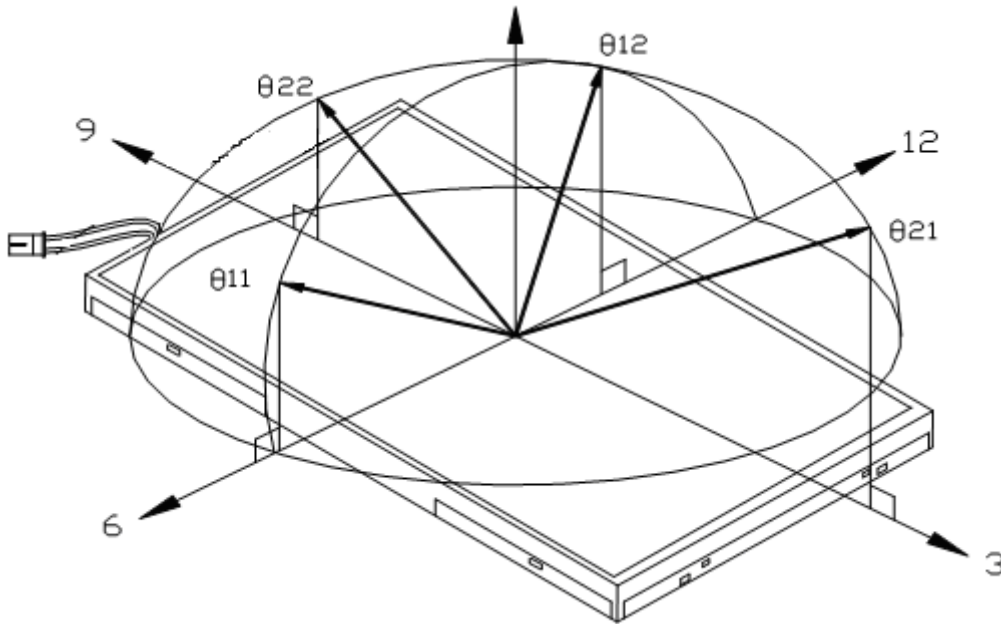

Note 13-2: The definition of contrast ratio $CR = \frac{\text{Luminance when Testing point is White}}{\text{Luminance when Testing point is Black}}$

Note 13-3: Definition of Response Time T_r and T_f :

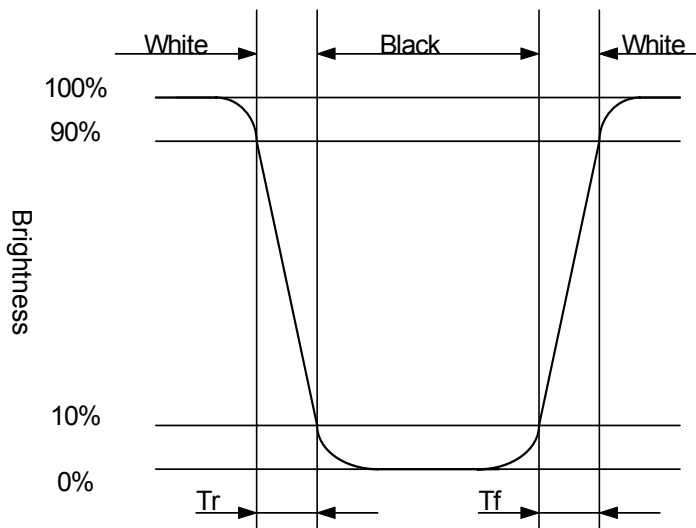

Note 13-4: The “LED Life time “ is defined as the module brightness decrease to 50% original Brightness that the ambient temperature is 25 and $I_{LED} = 176mA$

Note 13-5: The uniformity of LCD is defined as

$$U = \frac{\text{The Minimum Brightness of the 9 testing Points}}{\text{The Maximum Brightness of the 9 testing Points}}$$

Luminance meter: BM-5A or BM-7 fast (TOPCON)
 Measurement distance: 500 mm +/- 50 mm
 Ambient illumination: < 1 Lux
 Measuring direction: Perpendicular to the surface of module
 The test pattern is white.

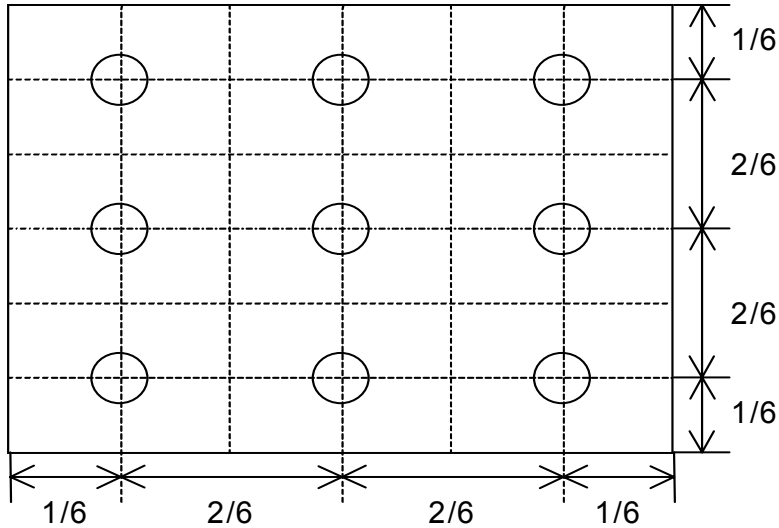

Note 13-6: Cross Talk (CTK) = $\frac{|YA-YB|}{YA} \times 100\%$

YA: Brightness of Pattern A
 YB: Brightness of Pattern B
 Luminance meter: BM 5A or BM-7 fast (TOPCON)
 Measurement distance: 500 mm +/- 50 mm
 Ambient illumination: < 1 Lux
 Measuring direction: Perpendicular to the surface of module

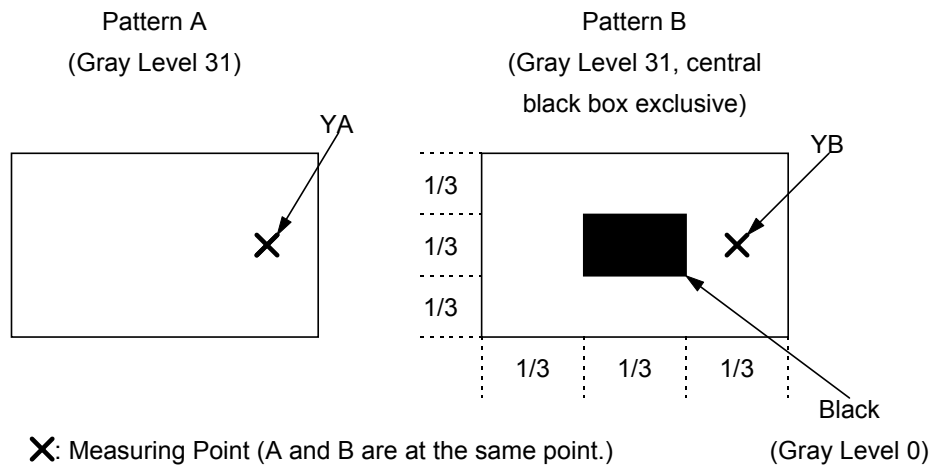

14. Handling Cautions**14-1) Mounting of module**

- a) Please power off the module when you connect the input/output connector.
- b) Polarizer which is made of soft material and susceptible to flaw must be handled carefully.
- c) Protective film (Laminator) is applied on surface to protect it against scratches and dirt's.
- d) Please following the tear off direction as figure14-1 to remove the protective film as slowly as possible, so that electrostatic charge can be minimized.

14-2) Precautions in mounting

- a) When metal part of the TFT-LCD module (shielding lid and rear case) is soiled, wipe it with soft dry cloth.
- b) Wipe off water drops or finger grease immediately. Long contact with water may cause discoloration or spots.
- c) TFT-LCD module uses glass which breaks or cracks easily if dropped or bumped on hard surface. Please handle with care.
- d) Since CMOS LSI is used in the module. So take care of static electricity and earth yourself when handling.

14-3) Adjusting module

- a) Adjusting volumes on the rear face of the module have been set optimally before shipment.
- b) Therefore, do not change any adjusted values. If adjusted values are changed, the specifications described may not be satisfied.

14-4) Others

- a) Do not expose the module to direct sunlight or intensive ultraviolet rays for many hours.
- b) Store the module at a room temperature place.
- c) The voltage of beginning electric discharge may over the normal voltage because of leakage current from approach conductor by to draw lump read lead line around.
- d) If LCD panel breaks, it is possibly that the liquid crystal escapes from the panel.
Avoid putting it into eyes or mouth. When liquid crystal sticks on hands, clothes or feet.
Wash it out immediately with soap.
- e) Observe all other precautionary requirements in handling general electronic components.
- f) Please adjust the voltage of common electrode as material of attachment by 1 module.

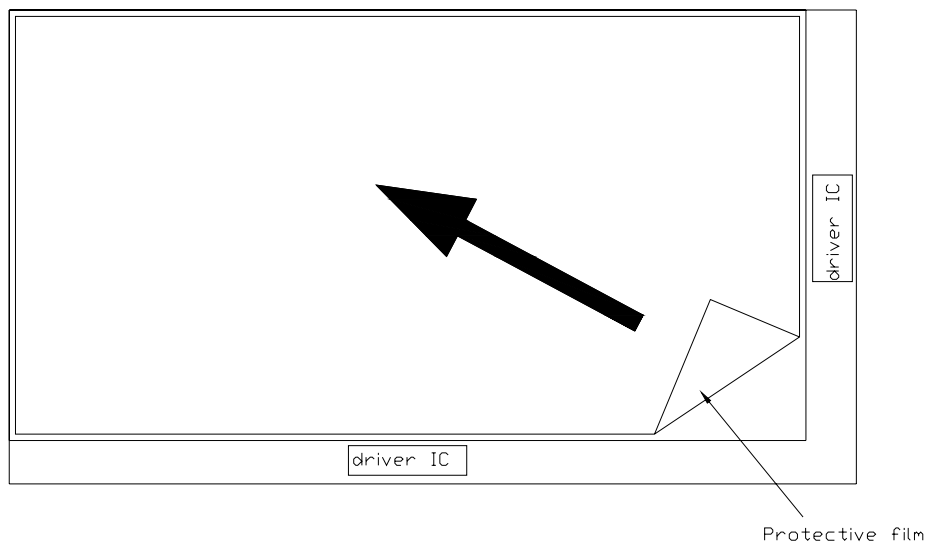

Figure 14-1 the way to peel off protective film

15. Reliability Test

No	Test Item	Test Condition
1	High Temperature Storage Test	Ta = +85□, 240 hrs
2	Low Temperature Storage Test	Ta = -40□, 240 hrs
3	High Temperature Operation Test	Ta = +80□, 240 hrs
4	Low Temperature Operation Test	Ta = -30□, 240 hrs
5	High Temperature & High Humidity Operation Test	Ta = +60□, 90%RH, 240 hrs (No Condensation)
6	Thermal Cycling Test (non-operating)	-30□→+80□, 100 Cycles 30min 30min
7	Vibration Test (non-operating)	Frequency : 10 ~ 55 Hz, Amplitude : 1 mm Sweep time: 11 min Test Period: 6 Cycles for each direction of X, Y, Z
8	Shock Test (non-operating)	100G, 6ms Direction: ±X, ±Y, ±Z Cycle: 3 times
9	Electrostatic Discharge Test (Operating)	C=150pF. R=330Ω. Contact=±8KV ; Air=±15KV 10times/point, 5 points/panel face

Ta: ambient temperature

Note: The protective film must be removed before temperature test.

[Criteria]

In the standard conditions, there is not display function NG issue occurred. (including : line defect ,no image), All the cosmetic specification is judged before the reliability stress.

16. Packing Diagram

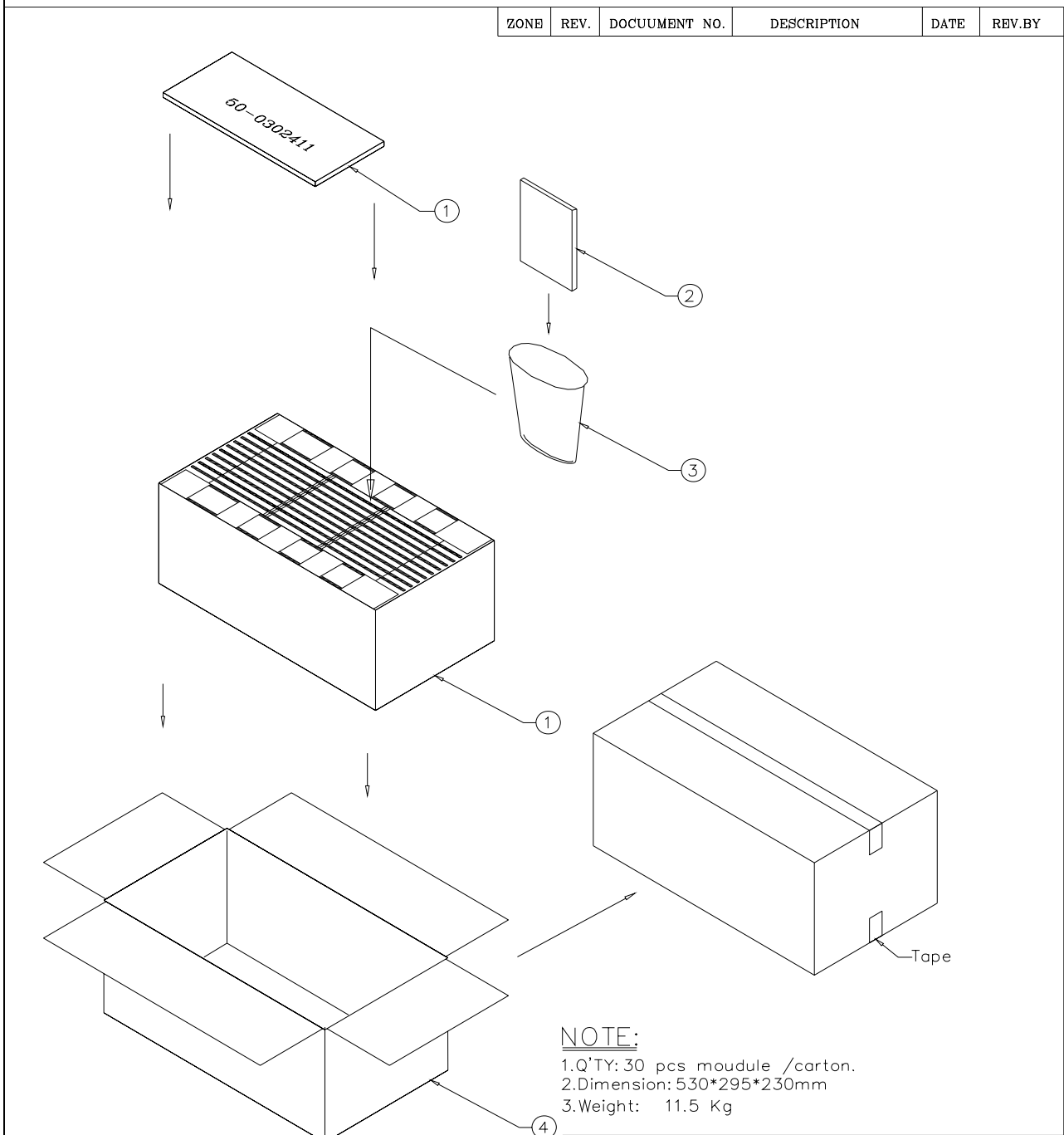

NOTE:
 1.Q'TY: 30 pcs module /carton.
 2.Dimension: 530*295*230mm
 3.Weight: 11.5 Kg

ITEM	PART NO.	DESCRIPTION	QTY	REMARK
4	50-0100111	CARTON	1	
3	50-0500071	靜電袋	30	抗靜電
2	PM070WM2		30	
1	50-0302411	瓦楞隔板緩衝材	1	上蓋+底座

MTL.SPEC.	UNSPECIFIED TOL'S	REMARK
	ANGLE	
	ROUGHNESS	

元太科技工業股份有限公司
 Prime View International Co., Ltd.

APPROVE	Frank shin	09.03.25	SCALE	UNIT	SHEET	DWG.TITLE
CHECK	Frank shin	09.03.25			1 OF 1	PM070WM2 Module Packing Draw
DRAWN	Joseph H	09.03.25	MTL.NO.	DWG FILE:	REV. 01	A4 SIZE